

CUI

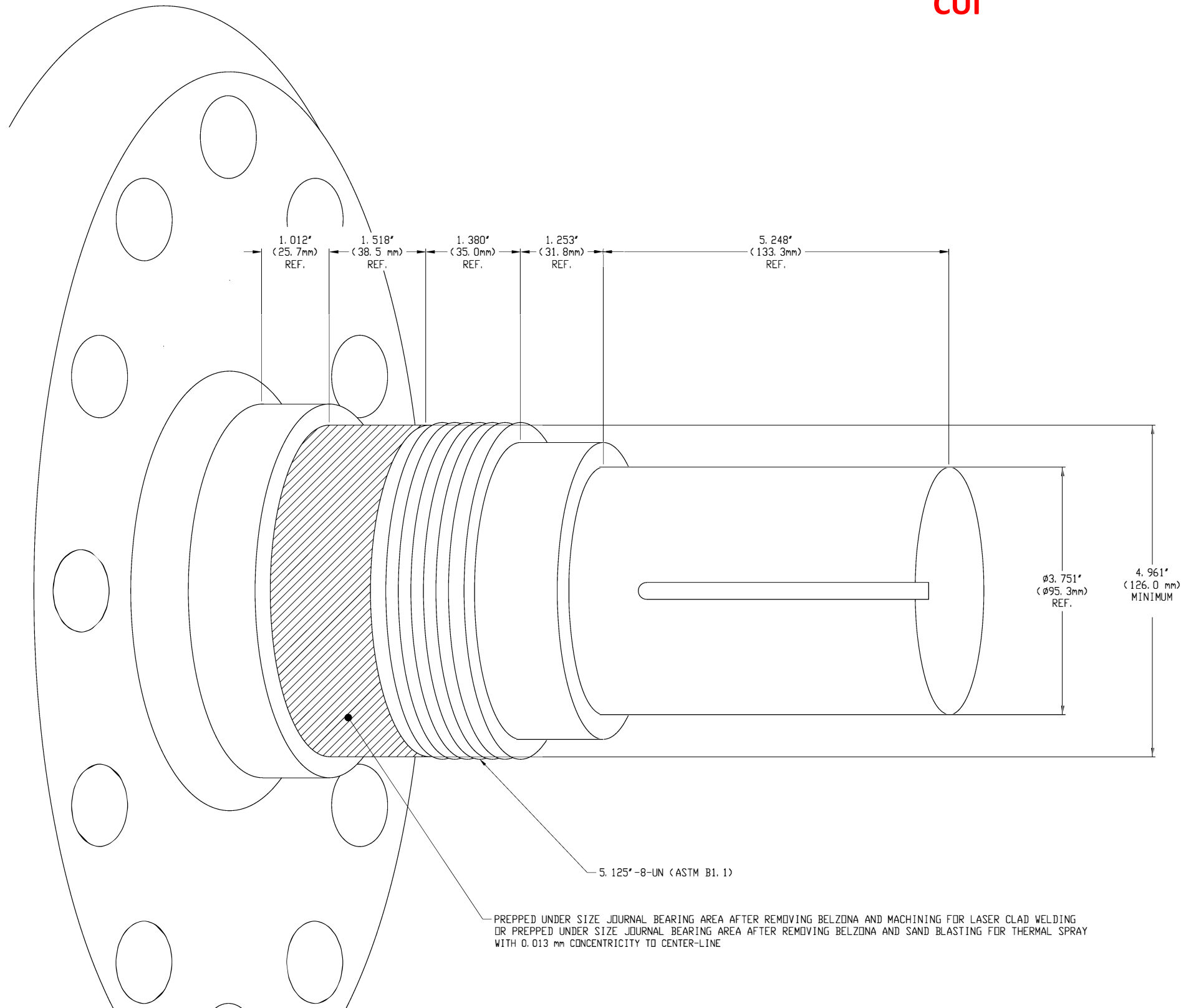

FLYWHEEL COUPLING END DETAIL
 AFTER REMOVING BELZONA AND MACHINING FOR LASER CLAD WELDING
 OR AFTER REMOVING BELZONA AND SAND BLASTING FOR THERMAL SPRAY
 PULSE FREQUENCY CHARGER
 SCALE: NONE

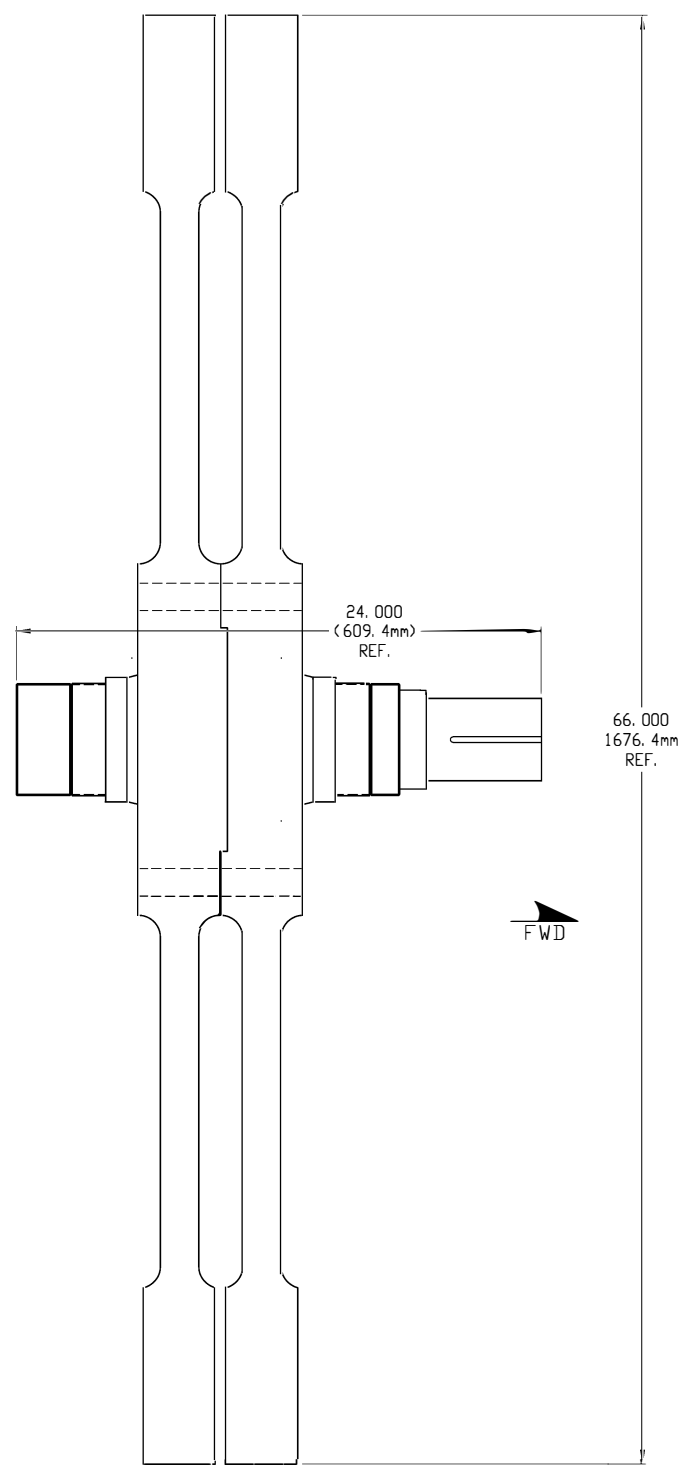

FLYWHEEL
 PULSE FREQUENCY CHARGER
 SCALE: NONE

**Thermal Spray Repair of Magnetic Minesweeping Gas Turbine
 Generator (MMGTG) Flywheel Sample Shaft**

Enclosure (3.2)

CUI