

CUI

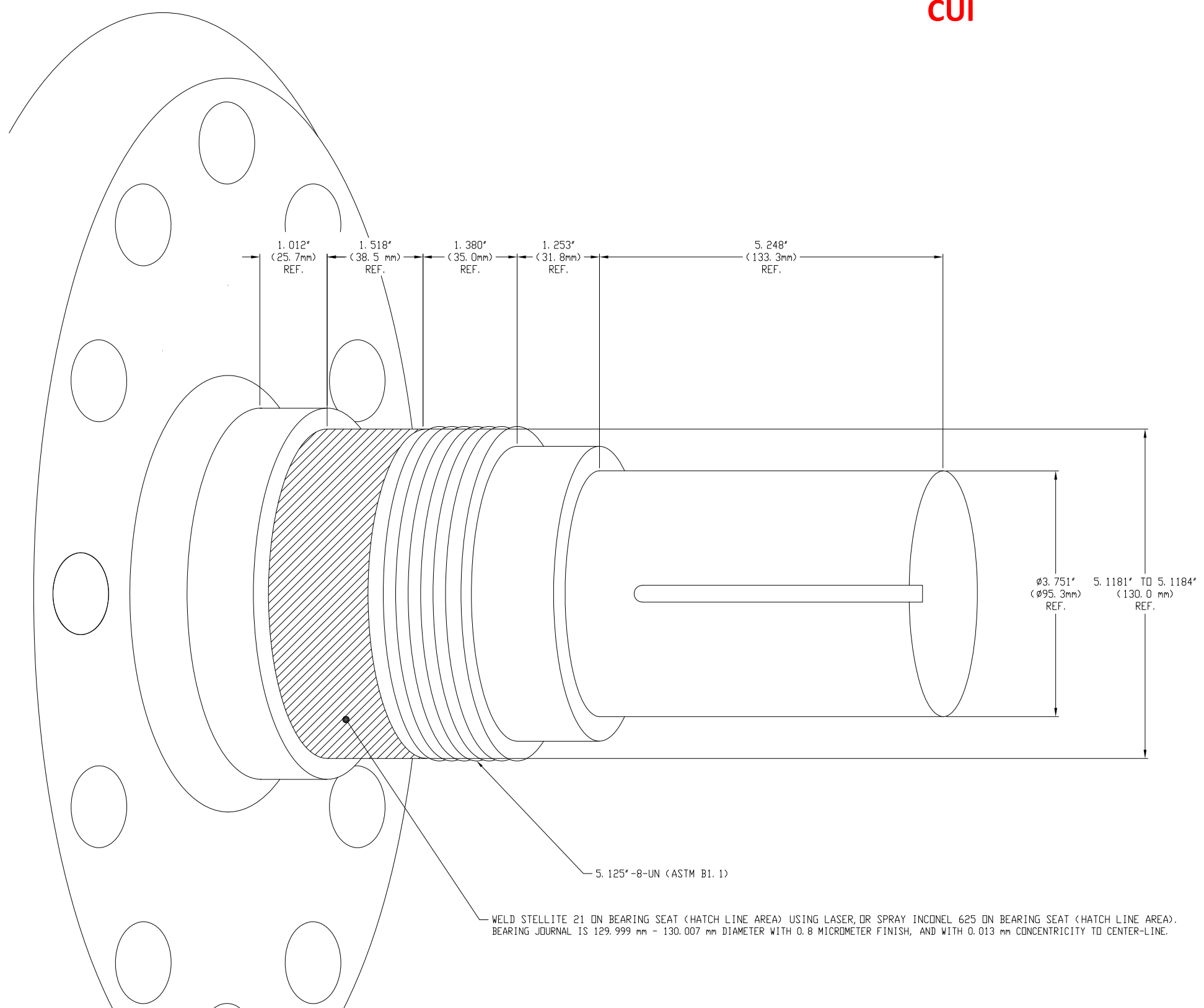

FLYWHEEL COUPLING END DETAIL AFTER LASER CLAD WELDING OR THERMAL SPRAY  
 PULSE FREQUENCY CHARGER  
 SCALE: NONE

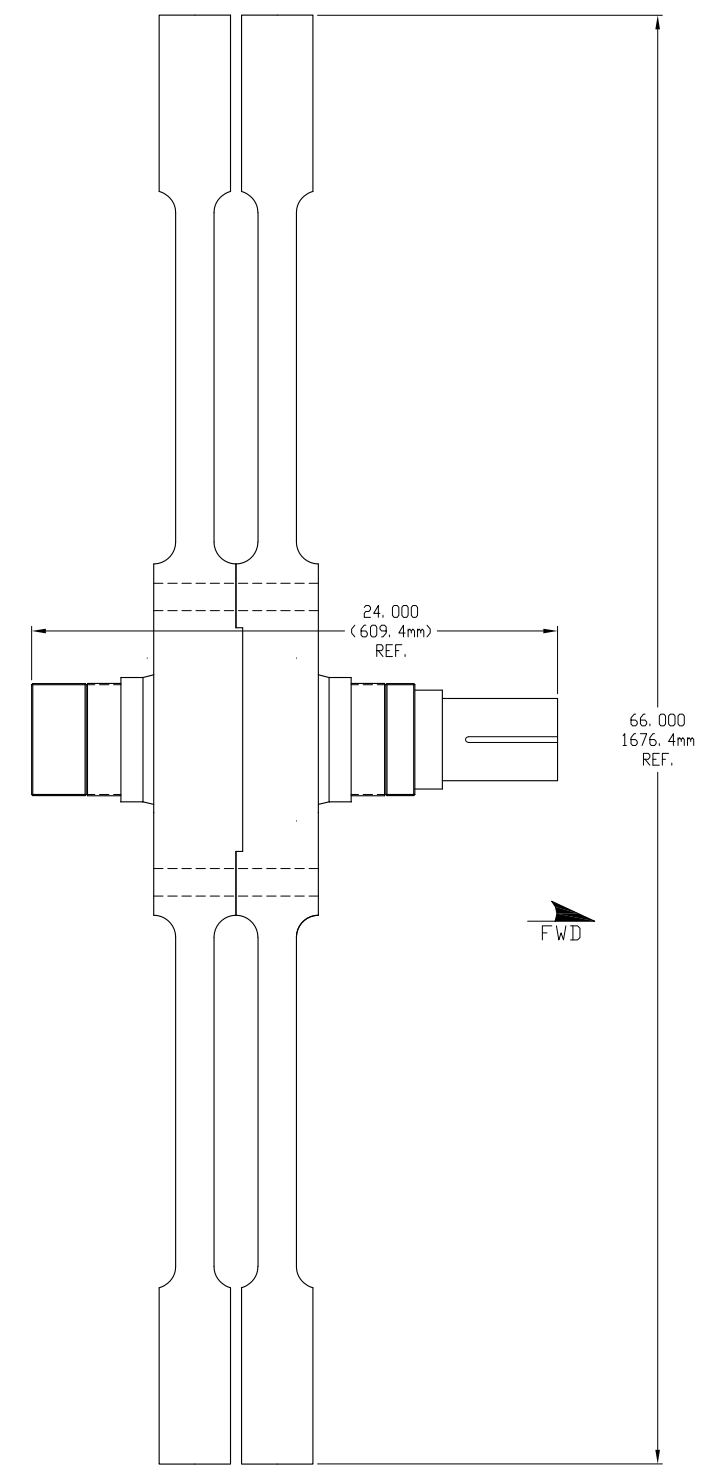

FLYWHEEL  
 PULSE FREQUENCY CHARGER  
 SCALE: NONE

**Thermal Spray Repair of Magnetic Minesweeping Gas Turbine Generator (MMGTG) Flywheel Sample Shaft**

CUI

Enclosure (3.1)